



**7630 BACK SUPPLY    7635 TOP SUPPLY**

## Front Mounted Wall Hung Washdown Urinal, Straddle Type

These Urinals are designed for areas where abuse and vandalism occurs. The urinals are fabricated using 14-gauge type 304 stainless steel welded to form a seamless durable fixture. Exposed surfaces are polished to a bright satin finish. Integral flushing rim provides a full sanitary washdown.

### INSTALLATION

Flush supply and waste piping must be roughed-in to the wall locations provided on drawings. Wall anchors (supplied by other manufacturers) are installed in the wall at locations shown on rough-in drawings. Concealed flush valve requires access for future flush valve service. Urinal is secured to the wall using studs and cap nuts. P-trap waste is connected to waste pipe, and trap enclosure is installed with stainless steel vandal resistant screws. Fixture meets A.D.A. requirements when installed per A.D.A. guidelines.

### RECOMMENDED FLUSH VALVES

|           | SLOAN    | ZURN        | DELANY |
|-----------|----------|-------------|--------|
| Concealed | 995-MBFW | ZH6195-MBFW | 1271   |
| Exposed   | 186      | Z6003       | 451    |

NOTE: Plan for service access to concealed flush valve.

### STANDARD FEATURES

- 7630 back supply connection 3/4" (19mm) MIPT.
- 7635 top supply connection 3/4" (19mm) MIPT.
- High volume beehive style strainer.
- 1 1/2" (38mm) OD P-trap for slip-type connection.
- Vandal resistant stainless steel trap enclosure.
- Integral mounting tabs for exposed anchoring.
- 3/8" (10mm) chrome plated vandal resistant cap nuts (4).
- 3/8" (10mm) steel studs for anchoring fixture to wall.



Unit may be pictured with some optional features.

### OPTIONS & ACCESSORIES

- A168** Metal template
- A245** Flush valve connector 3/4" (19mm) flush connection
- A610** Flush valve access panel  
13 1/2" (343mm) x 13 1/2" (343mm)

# METCRAFT

INDUSTRIES INC.



FIXTURE PLAN VIEW

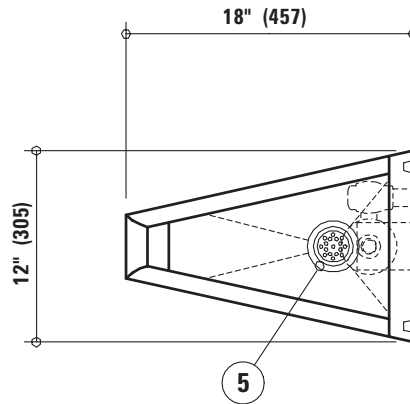

FIXTURE SIDE VIEW

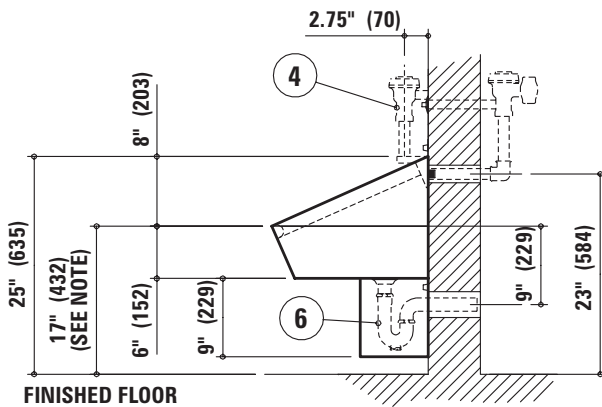

WALL ELEVATION VIEW (fixture side)

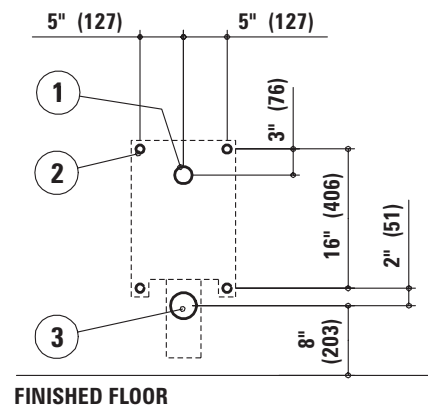

**ROUGH-IN INFORMATION**

- ① 2" (51mm) dia. wall opening for 3/4" (19mm) MIPT flush supply inlet (model #7630)
- ② Anchor locations supplied with (4) 3/8" x 2" (10mm x 51mm) threaded studs and tamper resistant cap nuts
- ③ 3" (76mm) dia. wall opening for waste outlet
- ④ 3/4" (19mm) MIPT top supply inlet (model #7635)
- ⑤ High volume beehive strainer
- ⑥ 1 1/2" (38mm) OD slip joint P-trap

NOTE: To mount urinal in accordance with "A.D.A." requirements the rim height must be mounted at 17" (432mm) above finished floor.

Due to continuous product improvement Metcraft reserves the right to make changes in design and specifications without prior notice. All dimensions should be verified with the factory for current information.

2004

