



4610 BACK SUPPLY 4615 TOP SUPPLY

Wall Hung, Blowout Type

These Toilet Fixtures are designed for high security areas without an accessible pipe chase. The fixtures are fabricated using heavy gauge type 304 stainless steel, seamlessly welded to form a one piece, vandal resistant unit. Internal piping is stainless steel. Exposed surfaces have a satin finish, except for the integral seat which is polished to a bright mirror finish.

PERFORMANCE

Metcraft bowls and assemblies are designed to withstand 5000 lb. (22kN) loading without permanent deflection and damage. They meet or exceed ASME 112.19.6M for hydraulic performance and ASME 112.19.2M for physical dimensions. The trap will pass a 2 5/8" (67mm) dia. ball. A minimum 1" (25mm) supply providing 25psi (172kPa) flushing pressure is required.

Water Consumption:

With a water saver flush valve - 3.5 gpf (13 liters)

With a low consumption flush valve - 1.6 gpf (6 liters)

INSTALLATION

The fixtures are designed for use with a standard blowout carrier (carrier is supplied by other manufacturers). They are supplied with three 7/8" (22mm) dia. mounting holes to accept 5/8" (16mm) studs and three tamper resistant cap nuts. The installer must provide wall openings for piping per rough-in drawings provided by Metcraft. Fixture meets A.D.A. requirements when installed per A.D.A. guidelines.

RECOMMENDED FLUSH VALVES

	SLOAN	ZURN	DELANY
Concealed water saver	952-MBFW	ZH6152-MBFW	1234
Concealed low consumption	952-1.5-MBFW	ZH6152-WS1-MBFW	1234-1.5
Exposed water saver	110	Z6000	439
Exposed low consumption	111	Z6000-1.5	439-1.5

NOTE: Plan for service access to concealed flush valve.



Unit may be pictured with some optional features.

STANDARD FEATURES

- Front mounted, wall hung.
- 4610 back supply connection 1 1/2" (38mm) FIPT.
- 4615 top supply connection 1 1/2" (38mm) MIPT.
- Integral elongated seat.
- Self draining flushing rim.
- Blowout flushing action.
- 3" (76mm) OD toilet waste tube with 5 1/2" (140mm) dia. recessed gasket flange.
- Fully enclosed trap.

OPTIONS & ACCESSORIES

- A168** Metal template
- HS** Hinged white plastic seat (no cover)
- A720** Wall mounted tissue holder

MODEL 4615 (TOP SUPPLY)

- A615** Flush valve enclosure

MODEL 4610 (BACK SUPPLY)

- A611** Flush valve access panel
15" (381mm) x 19" (483mm)

METCRAFT

INDUSTRIES INC.



FIXTURE PLAN VIEW

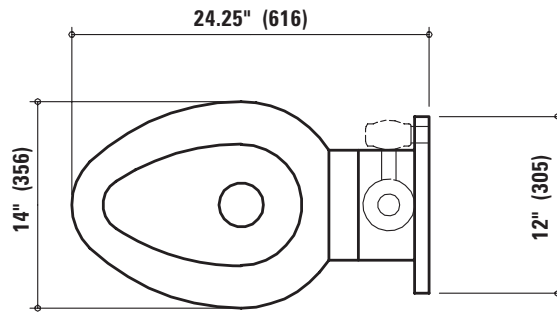

FIXTURE SIDE VIEW

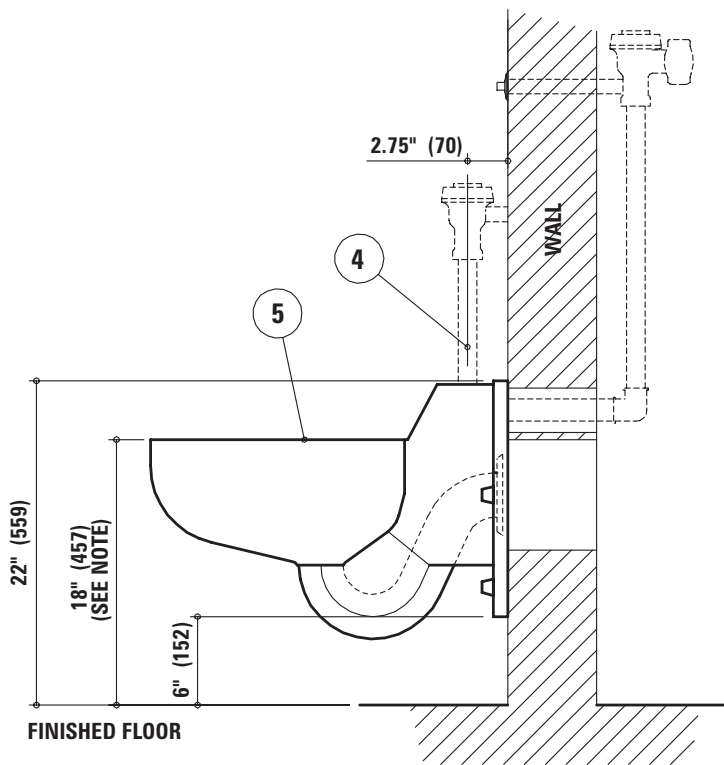

WALL ELEVATION VIEW (fixture side)

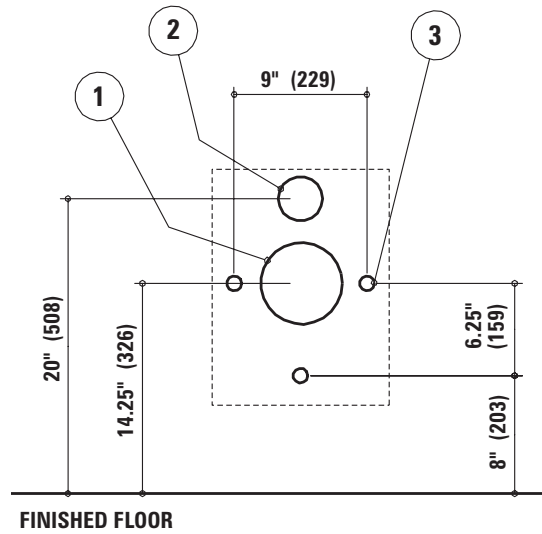

ROUGH-IN INFORMATION

- ① Flange location
 - ② 3" (76mm) wall opening for 1 1/2" (38mm) FIPT flush supply inlet (model #4610)
 - ③ Anchors locations (3)
 - ④ 1 1/2" (38mm) MIPT top supply inlet (model #4615)
 - ⑤ Mirror finish seat
- NOTE: Recommended seat height for A.D.A. compliance

Due to continuous product improvement Metcraft reserves the right to make changes in design and specifications without prior notice. All dimensions should be verified with the factory for current information.

2007



INDUSTRIES INC.