

DESCRIPTION

The 6981 hand wash sink is a wall mounted service sink fabricated from heavy gauge stainless steel as required for commercial applications. The unit fastens to the wall utilizing a "Z" clip hanger brackets and (2) matching stainless steel angle brackets. Overall size of sink is 48" x 20" (1219mm x 508mm)

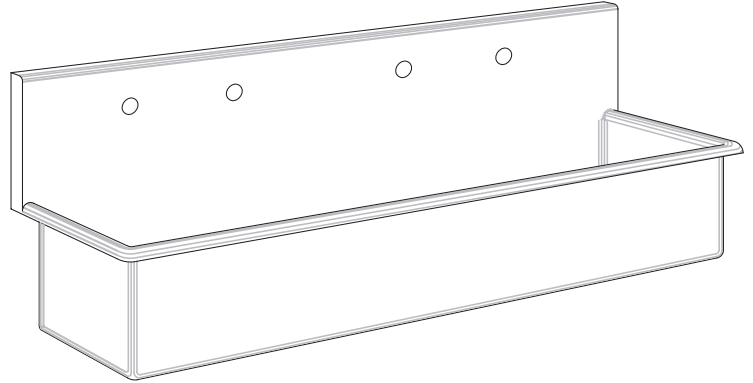

SPECIFICATION

The 6981 hand wash sink is fabricated from 16 gauge type 304 stainless steel polished to a # 4 satin finish. This fixture is constructed with 3/4" radiused coved corners. The sink is 8" deep with a die stamped bottom for positive drainage. The drain hole is 3-1/2". The backsplash is 10" high with a 2" flange returned to the wall on 3/4" radius. The faucet holes are 1-1/2" on 8" centers. The front and sides have 1-1/2" rolled rims joined into the backsplash.

Unit may be pictured with some optional features.

STANDARD FEATURES

- Fabricated from 16 gauge type 304 stainless steel polished to a #4 satin finish.
- 2 matching stainless steel angle brackets.
- 3/4" radiused coved corners.
- Die-stamped bottom for positive drainage.
- 1-1/2" diameter faucet holes on 8" centers.
- 3-1/2" die formed drain opening.

OPTIONS

- **A271** Flat strainer drain 1-1/2" IPS outlet.
- **SJP** Brass slip joint P-Trap waste with cleanout 1-1/2" IPS outlet.
- **A301** Surgical Sink Faucet.
- **A302** Single Sink Faucet.
- **SVP** Special Valve Punchings.

METCRAFT

INDUSTRIES INC.

FIXTURE PLAN VIEW

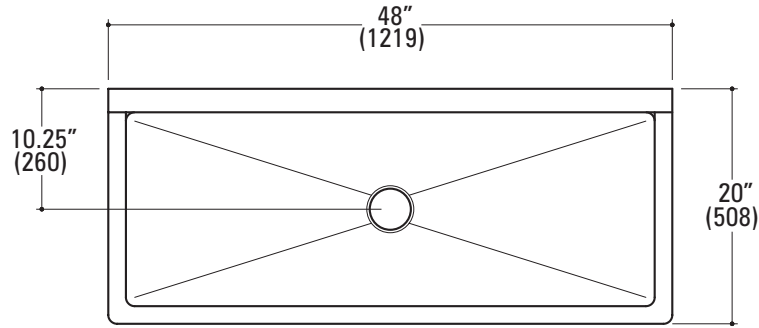

FIXTURE FRONT VIEW

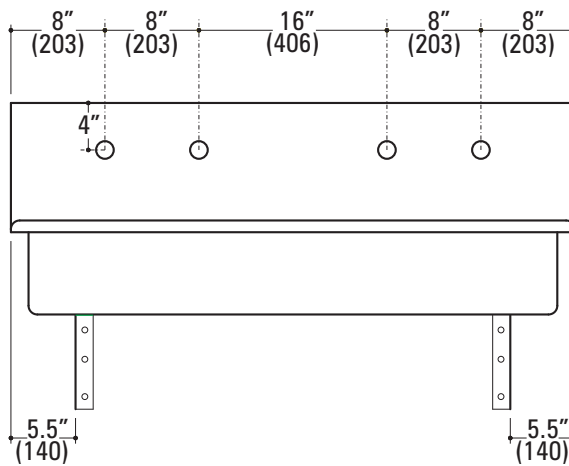

FIXTURE PARTIAL SECTION VIEW

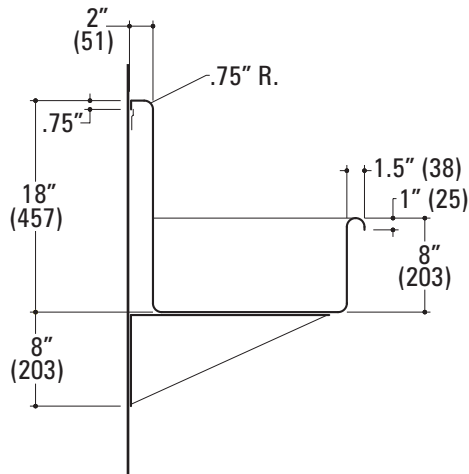

Due to continuous product improvement Metcraft reserves the right to make changes in design and specifications without prior notice. All dimensions should be verified with the factory for current information.

4/2004

