

## DESCRIPTION

The 6952 service sink is a wall mounted service sink fabricated from heavy gauge stainless steel as required for commercial applications. The unit fastens to the wall utilizing a "Z" clip hanger bracket and (2) matching stainless steel angle brackets. Overall size of sink is 26" x 21" (660mm x 533mm)

## SPECIFICATION

The 6952 service sink is fabricated from 16 gauge type 304 stainless steel polished to a # 4 satin finish. This fixture is constructed utilizing 3/4" radiused coved corners. The sink is 12" deep with a die stamped bottom for positive drainage. The drain hole is 3-1/2". The backsplash is 12" high with a 2" flange returned to the wall on 3/4" radius. The faucet holes are 1-1/2" on 8" centers. The front and sides have 1-1/2" rolled rims.

## STANDARD FEATURES

- Fabricated from 16 gauge type 304 stainless steel polished to a #4 satin finish.
- 2 matching stainless steel angle brackets.
- 3/4" radiused coved corners.
- Die-stamped bottom for positive drainage.
- 1-1/2" diameter faucet holes on 8" centers.
- 3-1/2" die formed drain opening.

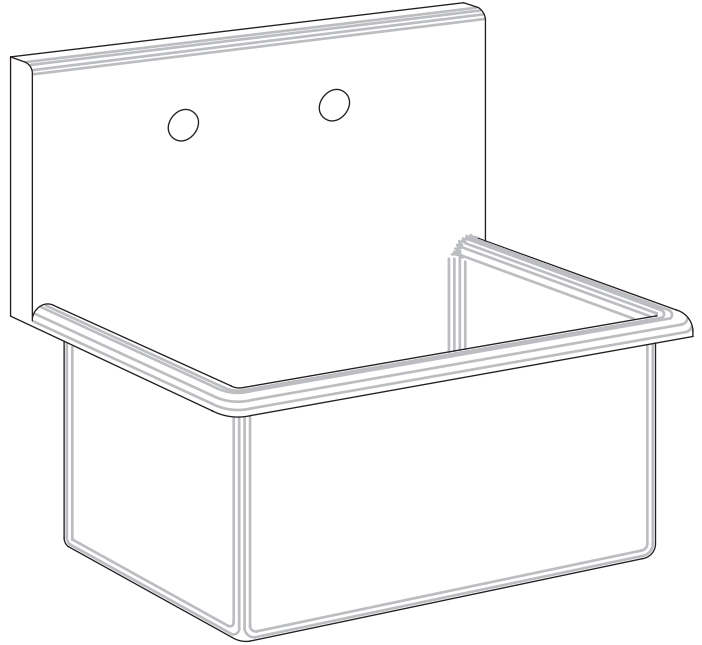

Unit may be pictured with some optional features.

## OPTIONS

- **A271** Flat strainer drain 1-1/2" IPS outlet.
- **A236** Cast Iron P-Trap 2" IPS outlet.
- **A303** Single Sink Faucet w/ Hose thread outlet.
- **A304** Service Sink Faucet w/ Vacuum breaker & hose thread outlet.
- **A305** Service Sink Faucet w/ Wall brace, Vacuum breaker & Hose thread outlet.

# METCRAFT

- I N D U S T R I E S I N C . -

### FIXTURE PLAN VIEW

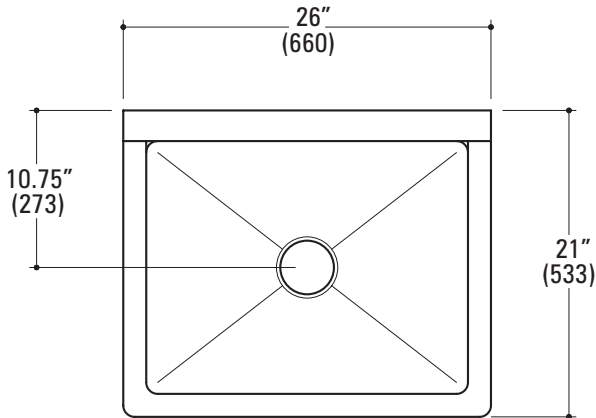

### FIXTURE FRONT VIEW

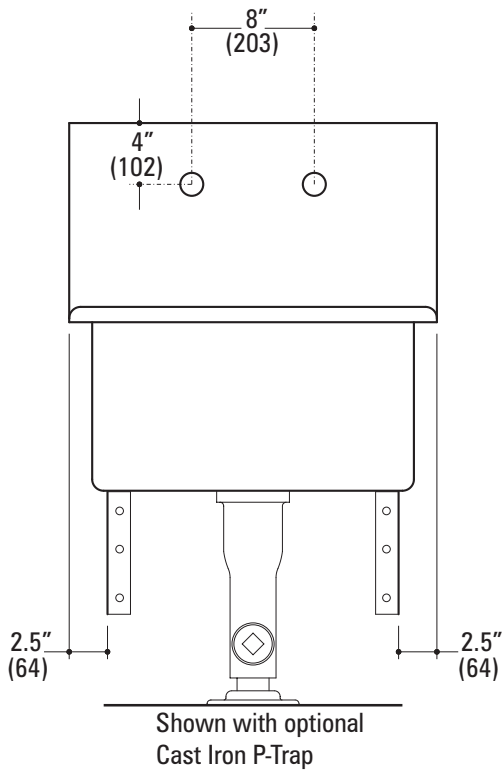

### FIXTURE PARTIAL SECTION VIEW

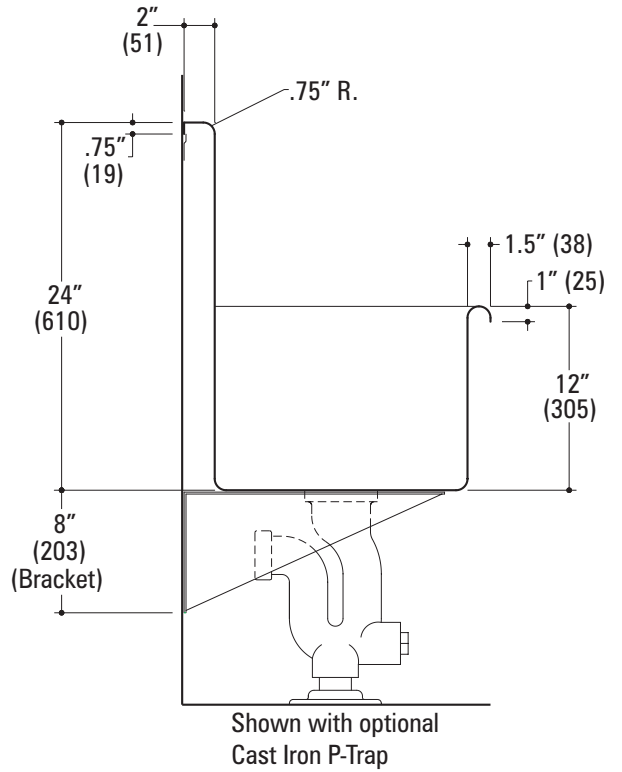

Due to continuous product improvement Metcraft reserves the right to make changes in design and specifications without prior notice. All dimensions should be verified with the factory for current information.

2/2004

# METCRAFT

INDUSTRIES INC.