



## 8650R/L

### Front Mounted Recessed Security Shower Panel

This Front Mounted Shower Panel is designed for use where no accessible chase exists. The panel is fabricated using 14-gauge type 304 stainless steel. Exposed surfaces are polished to a satin finish. Panel is secured to a 14-gauge type 304 stainless steel recessed wall box using stainless steel vandal resistant screws provided. Shower trim and valves are pre-mounted and tested at the factory before shipment. Connections are made to supply piping with flexible supply hoses through a supplied access panel after mounting the cover panel. Shower control valves and soap dish should be specified as required by application.

### INSTALLATION

The recessed wall box is built into the wall structure as a wall is being erected. Supply piping must be roughed into the box for final connection through a removable access panel on the installed cover panel. Knock out areas are provided at several locations in the wall box for this purpose. The shower head, valve and optional soap dish are pre-mounted to the shower panel. Valve supply inlets are provided with flexible hoses for connection to the supply piping. Hose fittings are 1/2" (13mm) FIPT with rubber seals. The shower panel is secured to the wall box using the vandal resistant stainless steel screws provided. Lower shower head must be mounted 48" (1219mm) above finished floor to comply with A.D.A. guidelines. Fixture meets A.D.A. requirements when installed per A.D.A. guidelines.

### STANDARD FEATURES

- 30 degree security shower head with vandal resistant adjustable spray (2).
- Recessed steel mounting box.
- Stainless steel vandal resistant mounting screws for front cover.
- Flexible supply hoses for easy connection.
- Manifoldd single temperature pushbutton pneumatic metering valve with strainer/checkstop. One pushbutton controls upper shower head and a second pushbutton controls lower shower head.
- 2.5 gallon per minute flow

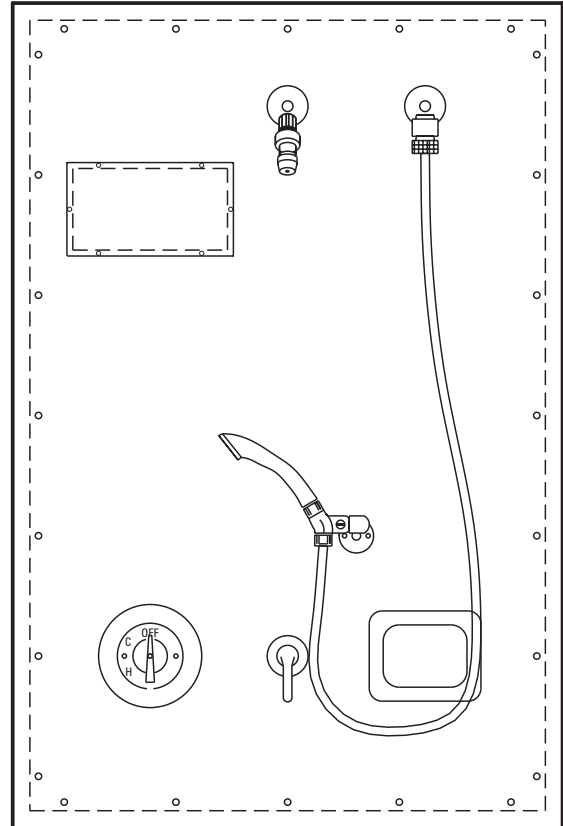

Unit may be pictured with some optional features.

### OPTIONS & ACCESSORIES

- S0** Recessed soap dish
- A501** Surface mounted soap dish
- A385** Liquid soap valve
- PSH-2** Shower head 17 1/2 degree
- A314-2** Hot & cold, manifolded pneumatic valve
- FC20** 2.0 gallon per minute flow
- LHD** Lever handle diverter valve
- 205** Pressure balanced mixing valve
- 206** Hand shower with vacuum breaker
- 207** Quick disconnect for hand shower

# METCRAFT

INDUSTRIES INC.

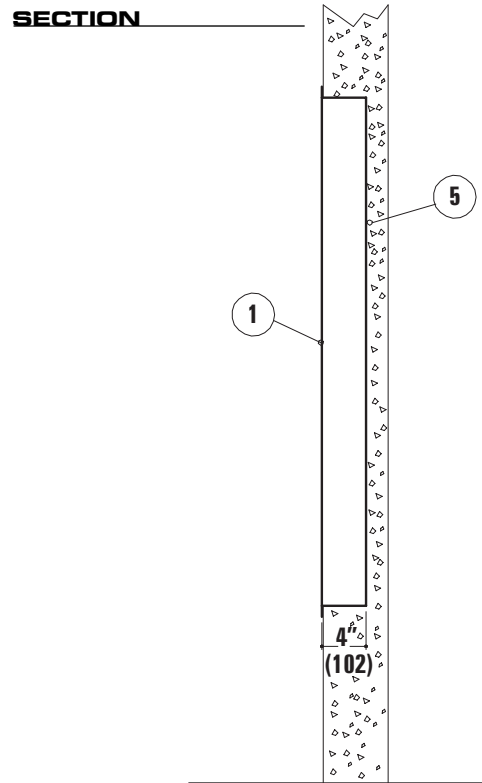
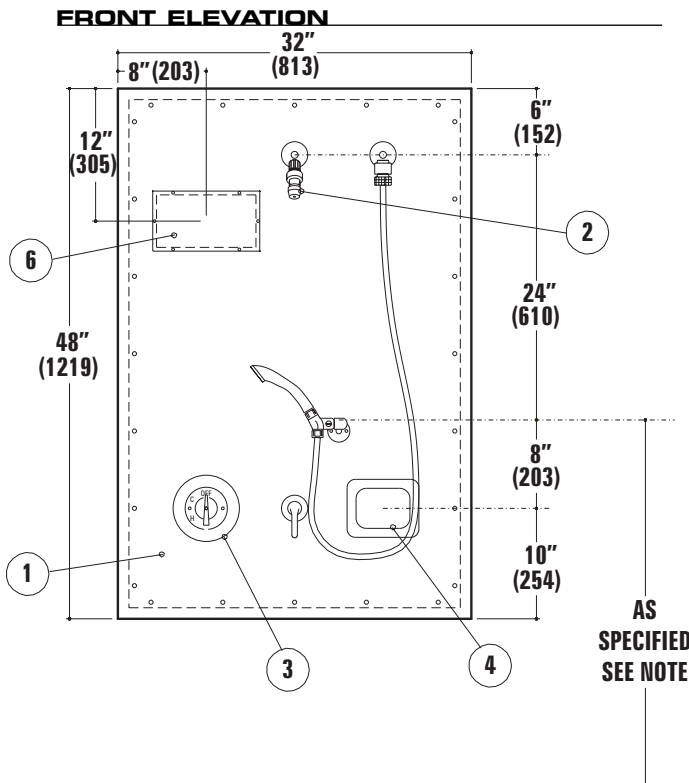

**CONCEALED BOX ROUGH-IN LOCATIONS**

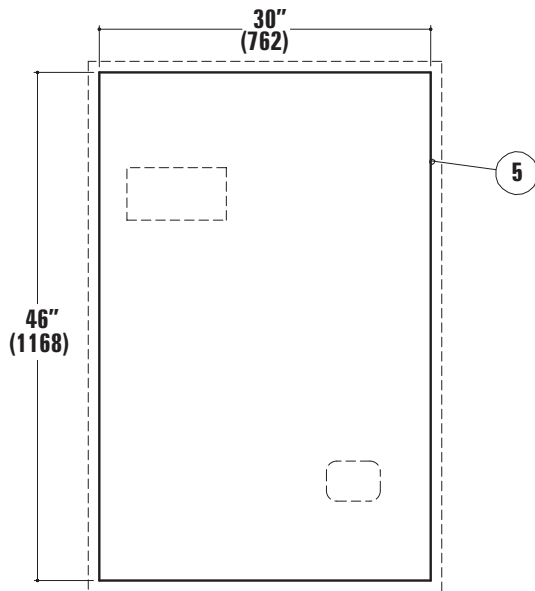

Left Hand Fixture is Shown.  
Right Hand Fixture is Reversed.

**ROUGH-IN INFORMATION**

- ① Cover panel
- ② Penal shower heads
- ③ Valve actuators
- ④ Recessed soap dish
- ⑤ Recessed wall box
- ⑥ Access Panel

NOTE: To mount shower in accordance with "A.D.A." requirements the lowest showerhead should be mounted at 48" (1219mm) above the finished floor. The height for the second showerhead will be 72" (1829mm) above the finished floor.

Due to continuous product improvement Metcraft reserves the right to make changes in design and specifications without prior notice. All dimensions should be verified with the factory for current information.

2004

