



5691

Front Mounted Security Drinking Fountain

This Drinking Fountain is designed for areas without an accessible pipe chase. The fixture is fabricated using heavy gauge type 304 stainless steel seamlessly welded to form a one piece vandal resistant unit. The fixture is furnished with a 4" (102mm) high backsplash. The bottom enclosure plate is removable and secured with stainless steel tamper resistant screws. Exposed surfaces have a satin finish. Fixture is furnished with a security type chrome plated brass bubbler head, a pneumatic pushbutton control valve with a .5 GPM flow control and a slip-joint P-trap. Valve and P-trap are installed inside fixture. Pushbutton requires less than 5 lbs (2.2N) to activate valve.

INSTALLATION

Supply and waste piping are roughed in at wall locations shown on drawings provided by Metcraft. Wall anchors (not furnished) must be embedded in the wall at mounting locations shown on drawings. The fixture is mounted to the wall using a hanger bracket and bolts furnished with the fixture. Piping connections are made through the removable bottom access plate, which is secured in place with the vandal resistant fasteners provided. Fixture meets A.D.A. requirements when installed per A.D.A. guidelines.



Unit may be pictured with some optional features.

STANDARD FEATURES

- Deep rectangular splash basin with multi-hole integral drain.
- Heavy duty chrome plated vandal resistant bubbler head.
- Security type pushbutton pneumatic control valve with .5 GPM flow restrictor.
- 1½" (38mm) OD slip joint P-trap.
- 4" (102mm) high back splash.
- Removable bottom enclosure with stainless steel, vandal resistant screws.

OPTIONS & ACCESSORIES

A168 Metal template

METCRAFT
INDUSTRIES INC.



FIXTURE PLAN VIEW

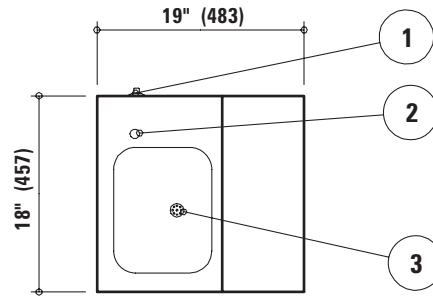

FIXTURE SIDE VIEW

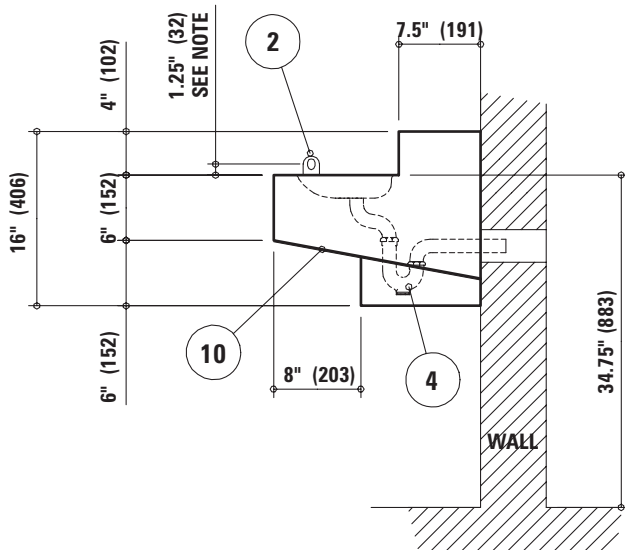

WALL ELEVATION VIEW (fixture side)

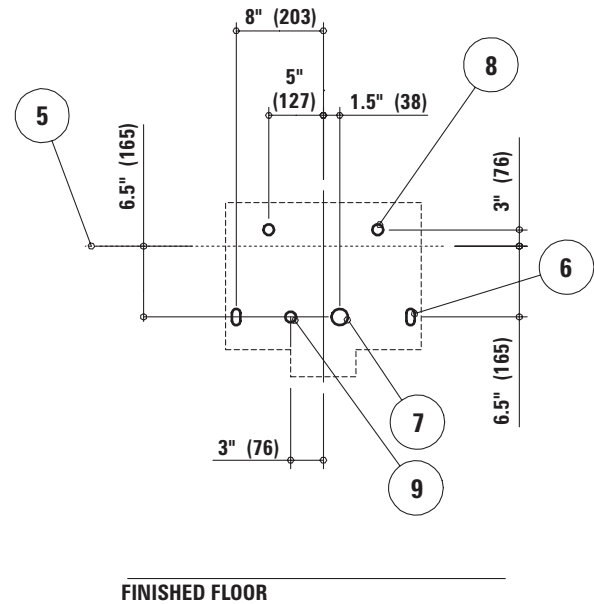

ROUGH-IN INFORMATION

- ① Valve pushbutton
- ② Security type bubbler head
- ③ Fast drain
- ④ Plumbing components
- ⑤ Drinking fountain rim height
- ⑥ Anchor locations with 1/2" (13mm) wall fasteners (2)
- ⑦ Waste outlet
- ⑧ Anchor locations with 1/2" (13mm) wall fasteners for wall bracket (2)
- ⑨ Valve water supply connection
- ⑩ Tamper resistant removable bottom

NOTE: To mount lavatory in accordance with "A.D.A." requirements the rim height must be mounted at 34 3/4" (883mm) above finished floor.

Due to continuous product improvement Metcraft reserves the right to make changes in design and specifications without prior notice. All dimensions should be verified with the factory for current information.

2007

